

CityCat V20e

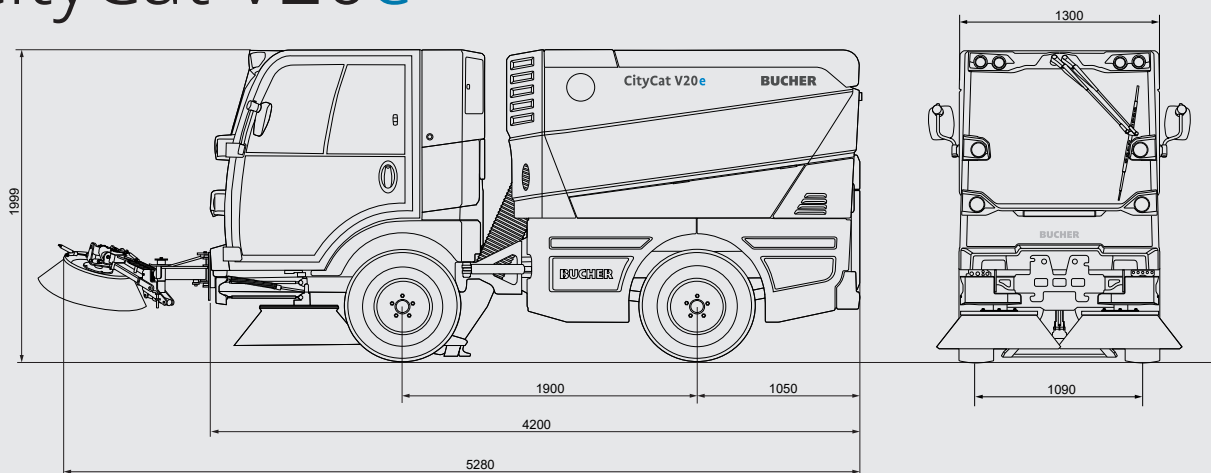

Dimensions

Length	4200 mm
Width	1300 mm
Height	1999 mm
Wheelbase	1900 mm
Track width	1090 mm
Cleaning width	2100 mm
Cleaning width 3rd brush	2700 mm

Weight

Empty weight	2700 kg
Payload	2100 kg
GVW	4800 kg

Emissions

Noise level L_{WA}	92 dB(A)
PM certification	PM 2.5/PM10 ****

Tyres

215/75 R16 C M+S

Drive system

Working speed	0-15 km/h
Travelling speed	0-50 km/h*
Climbing ability	up to 30 %
Electric drive	45 kW
Electric fan	8.5 kW
Electric hydraulic aggregate	12 kW

HV Battery

Battery type	Li-ion
Battery capacity	63 kWh
Nominal voltage	335 Volt
Operating time	up to 8 hours

Charging system

Internal charger	22 kW
Charger inlet	Type 2
Charging time	2 to 3 hours

* According to national legislation

CityCat V20e: the agile compact sweeper



Ready for action at any time

The HV battery can be recharged in just two to three hours at any public car charging station thanks to a 22 kW on-board charger.



Choose your settings

The CSense display (10.1 inch touch display) with intuitive design for extended functions, central overview of all settings and visual diagnostic system. The displayed vehicle set-up can be individually chosen by the driver.



Maximum service life

The exceptionally robust and maintenance-free design of the HV battery ensures maximum service life in daily operation and minimum deterioration of the cells.

CityCat V20e

Chassis

Two-part ladder-type frame chassis with "C" profile construction. Independent suspension with shock absorber and screw spring on the front axle and leaf suspension with shock absorber on the rear axle.

Axles and steering

Electrically driven front axle with self-locking differential gear (Torsen differential gear). Articulated steering with load-sensing steering hydraulics.

Working hydraulics

Electrically driven hydraulic unit with silent gear pumps for steering, auxiliary functions, side and front brush drive.

Brakes

Hydraulic servo dual-circuit brake system with disc brakes on front and rear axle. Parking brake (spring-energy brake) acting on the front axle.

Cab

Comfortably suspended sound-insulated aluminium cab. Windscreen made of heat-reflecting, curved, low-reflection safety glass. Two sliding windows in each door. Variable heater, sun screens, screen wiper with washer. Individually adjustable, sprung driver's seat with headrest and 3-point safety belt. Angle- and height-adjustable steering column.

Control unit

Smart-Con operation concept includes a multi-functional armrest with smart start function makes it possible to operate all working functions with one hand. All relevant information at a glance at any time thanks to the digital 4.3 inch display. CSense display (10.1 inch touch display) with intuitive design for extended functions, central overview of all settings and visual diagnostic system. The displayed vehicle set-up can be individually chosen by the driver.

Water system

Water volume	425 l
Fresh water volume	275 l
Service water volume	150 l

The water tank for service water can optionally be used as expansion for fresh water. Electrically controlled water pump for the water nozzles.

Hopper

Container made of stainless steel, can be tilted and closed hydraulically

Volume	2.0 m ³
Dumping height	1555 mm
Dumping width	1043 mm

Sweeping system

Wide suction mouth floating between the front wheels, made of cast aluminium hanging on a patented compensation mechanism. Adjustable high-performance suction fan.

Brushes

2 side brushes left and right Ø 800 mm

Speed adjustment 0-120 U/min

Impact-proof brush suspension.

3rd front brush for cleaning width of 2700 mm and for cleaning corners and ramps, can be used on the left and right (optional).

Options

- Air conditioning
- Rear view and suction mouth camera
- Radio with Bluetooth & DAB+
- Hydraulically tiltable side brushes
- Side brush single lift
- Wander hose
- Weed brush
- Water flushing bar
- High pressure water system
- EasyClean system
- LED work light
- Data capture

A variety of other options are available – contact us for more information.

Subject to change without notice.



Bucher Municipal AG

Murzlenstrasse 80
CH-8166 Niederweningen
Tel. +41 44 857 22 11
Fax +41 44 857 24 10
info.ch@buchermunicipal.com

www.buchermunicipal.com



Bucher
Municipal
E-Shop

Driven by better